

Diffuse with background suppression maximum sensing distance

20...60 mm

20...60 mm

Retroreflective with polarizing filter maximum range

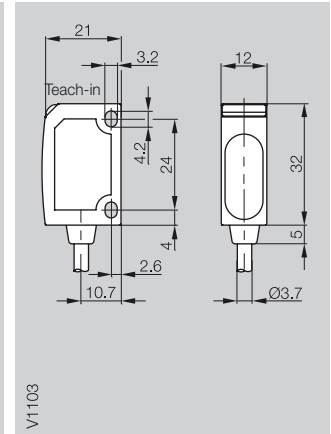
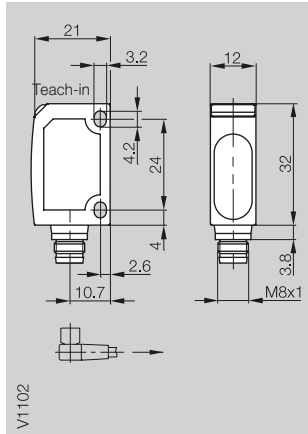

Diffuse



PNP	20...60 mm	HGA
NPN	20...60 mm	HGA
PNP	30...110 mm	HGA
NPN	30...110 mm	HGA

BOS 6K-PU-1LHA-S75-C
BOS 6K-NU-1LHA-S75-C

BOS 6K-PU-1LHA-C-02
BOS 6K-NU-1LHA-C-02

Reflexionslichtschranke



PNP	0.05...1.5 m	Polarizing filter
NPN	0.05...1.5 m	Polarizing filter

Electrical data

Supply voltage U_B	10...30 V DC
No-load supply current I_0 max.	≤ 25 mA
Switching output	PNP- or NPN-Transistor
Output current	100 mA
Switching type	Light-/dark-on (selectable)
Voltage drop U_d at I_e	≤ 2.4 V
Settings	teach-in

10...30 V DC
≤ 25 mA
PNP- or NPN-Transistor
100 mA
Light-/dark-on (selectable)
≤ 2.4 V
teach-in

10...30 V DC
≤ 25 mA
PNP- or NPN-Transistor
100 mA
Light-/dark-on (selectable)
≤ 2.4 V
teach-in

Optical data

Recommended sensing distance/range	20...60 mm
Emitter, light type	Laser, red light
Wavelength	650 nm
Laser class	1
Light spot diameter	0.5 mm at focus (35 mm)
Distance hysteresis (18 %/18 %)	≤ 2 % up to focal point, ≤ 6 % up to end
Gray value shift (90 %/18 %)	≤ 7 %

20...60 mm
Laser, red light
650 nm
1
0.5 mm at focus (35 mm)
≤ 2 % up to focal point, ≤ 6 % up to end
≤ 7 %

20...60 mm
Laser, red light
650 nm
1
0.5 mm at focus (35 mm)
≤ 2 % up to focal point, ≤ 6 % up to end
≤ 7 %

Indicators

Switching state indicator	LED yellow
Stability indicator	LED green

LED yellow
LED green

LED yellow
LED green

Time data

Response time	0.5 ms
Switching frequency f	1 kHz

0.5 ms
1 kHz

0.5 ms
1 kHz

Mechanical data

Dimensions	21×32×12 mm
Connection	M8 connector, 4-pin
No. of wires × cross-section	4×0.14 mm ²
Housing material	impact-resistant ABS
Optical surface	PMMA
Weight	10 g

21×32×12 mm
M8 connector, 4-pin
4×0.14 mm ²
impact-resistant ABS
PMMA
10 g

21×32×12 mm
2 m cable, PVC
4×0.14 mm ²
impact-resistant ABS
PMMA
40 g

Ambient data

Degree of protection per IEC 60529	IP 67
Polarity reversal protected	yes
Short circuit protected	yes
Ambient temperature range T_a	-20...+60 °C
Ambient light limit	EN 60947-5-2

IP 67
yes
yes
-20...+60 °C
EN 60947-5-2

IP 67
yes
yes
-20...+60 °C
EN 60947-5-2

Diffuse values referenced to Kodak gray card 18% Reflexion.
Retroreflective values referenced to R22 reflector.

Wiring diagrams, characteristics and accessories see page 2.1.128 and 2.1.129.

¹⁾ $U_{imp} = 500 V$

mini.s Laser with teach-in



Photoelectric Sensors

BOS 6K Laser
Sensing distance 110 mm
Range 1,5 m

30...110 mm

30...110 mm

0,05...1,5 m

0,05...1,5 m

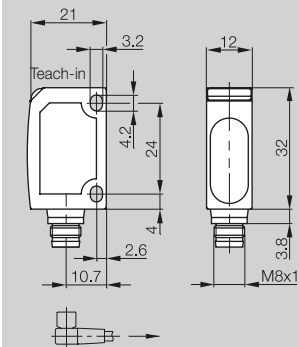

V1102

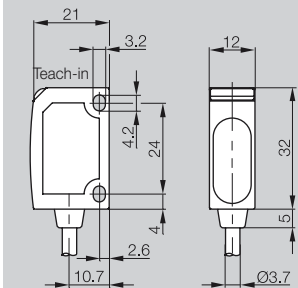

V1103

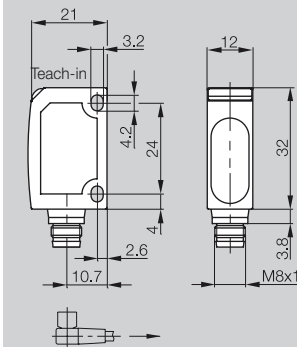

V1102

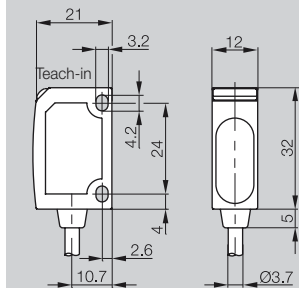

V1103

BOS 6K-PU-1LHA-SA1-S75-C
BOS 6K-NU-1LHA-SA1-S75-C

BOS 6K-PU-1LHA-SA1-C-02
BOS 6K-NU-1LHA-SA1-C-02

BOS 6K-PU-1LQA-S75-C
BOS 6K-NU-1LQA-S75-C

BOS 6K-PU-1LQA-C-02
BOS 6K-NU-1LQA-C-02

10...30 V DC
≤ 25 mA
PNP- or NPN-Transistor
100 mA
Light-/dark-on (selectable)
≤ 2.4 V
teach-in

10...30 V DC
≤ 25 mA
PNP- or NPN-Transistor
100 mA
Light-/dark-on (selectable)
≤ 2.4 V
teach-in

10...30 V DC
≤ 25 mA
PNP- or NPN-Transistor
100 mA
Light-/dark-on (selectable)
≤ 2.4 V
teach-in

10...30 V DC
≤ 25 mA
PNP- or NPN-Transistor
100 mA
Light-/dark-on (selectable)
≤ 2.4 V
teach-in

30...110 mm
Laser, red light
650 nm
2
0,7 mm at focus (85 mm ± 15 mm)
≤ 5 % up to focal point, ≤ 7 % up to end
≤ 7 %

30...110 mm
Laser, red light
650 nm
2
0,7 mm at focus (85 mm ± 15 mm)
≤ 5 % up to focal point, ≤ 7 % up to end
≤ 7 %

0.05...1 m
Laser, red light
650 nm
1
1 mm in 300 mm

0.05...1 m
Laser, red light
650 nm
1
1 mm in 300 mm

LED yellow
LED green

LED yellow
LED green

LED yellow
LED green

LED yellow
LED green

0.5 ms
1 kHz

0.5 ms
1 kHz

0.5 ms
4 kHz

0.5 ms
4 kHz

21×32×12 mm
M8 connector, 4-pin

21×32×12 mm
2 m cable, PVC
4×0.14 mm²

21×32×12 mm
M8 connector, 4-pin

21×32×12 mm
2 m cable, PVC
4×0.14 mm²

impact-resistant ABS
PMMA
10 g

impact-resistant ABS
PMMA
40 g

impact-resistant ABS
PMMA
10 g

impact-resistant ABS
PMMA
40 g

IP 67
yes
yes

IP 67
yes
yes

IP 67
yes
yes

IP 67
yes
yes

-20...+60 °C
EN 60947-5-2

-20...+60 °C
EN 60947-5-2

-20...+60 °C
EN 60947-5-2

-20...+60 °C
EN 60947-5-2



Connector orientation

2.1

2.3

Photoelectric
Sensors
Accessories
Page 2.3.2 ...

5

Connectors ...
Page 5.2 ...

Diffuse BOS 6K-...-1HA-...

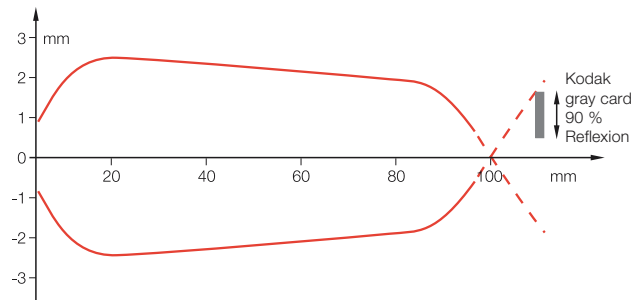

Range measured with side approach of Kodak gray card.

Retroreflective BOS 6K-...-1QA-...

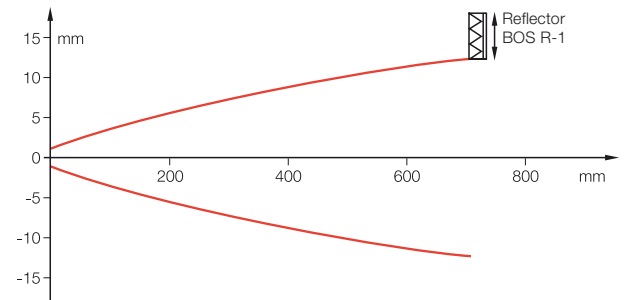

Range measured with side approach of reflector.

Diffuse BOS 6K-...-1OC-...

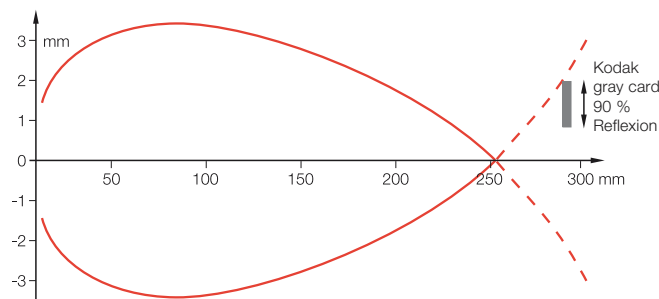

Range measured with side approach of Kodak gray card.

Retroreflective BOS 6K-...-1QC-...

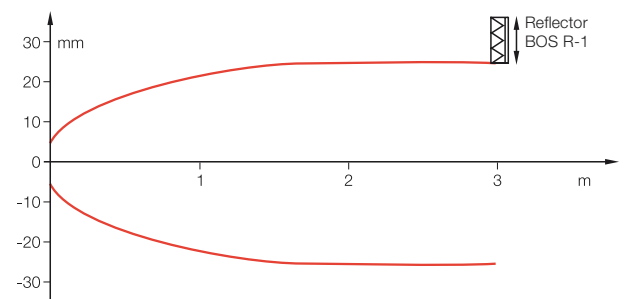

Range measured with side approach of reflector.

Diffuse BOS 6K-...-1LHA-...

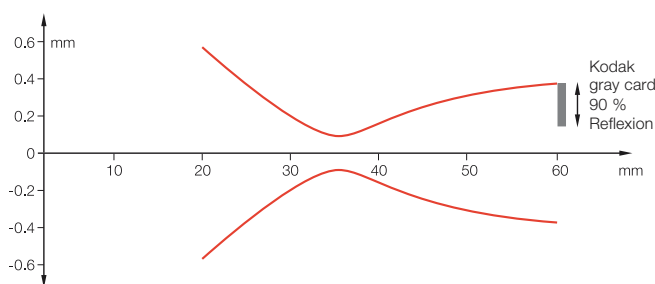

Range measured with side approach of Kodak gray card.

Retroreflective BOS 6K-...-1LQA-...

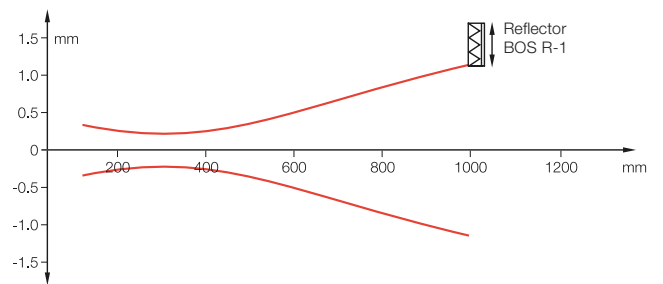

Range measured with side approach of reflector.

Wiring diagrams

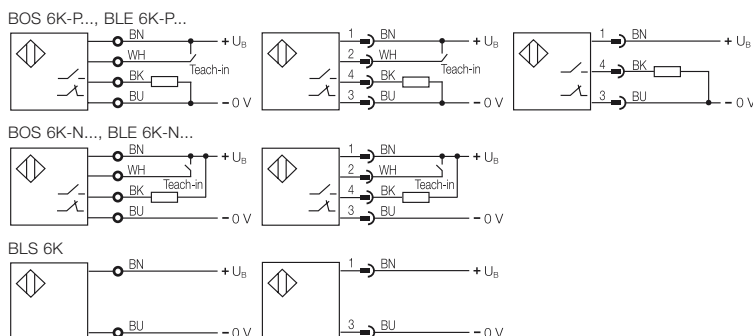

Diffuse

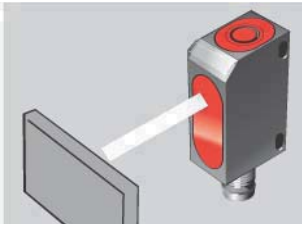

Align sensor with the object.



Press button for approx. 3 sec. until both LED's blink together.

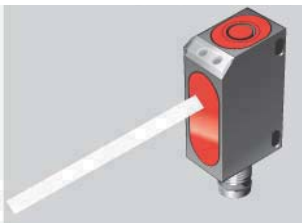

Remove object from beam path.



Hold down button for 1 sec. Green LED blinks briefly and then comes full on. The sensor is ready. If both LEDs blink together, repeat your settings.

Retroreflective/through-beam

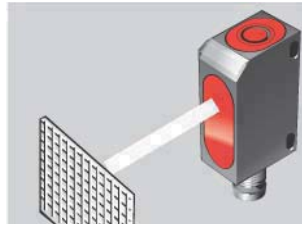

Direct sensor at reflector/receiver.



Press button for approx. 3 sec. until both LED's blink together.

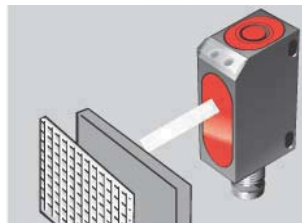

Bring objects into detection range.



Hold down button for 1 sec. Green LED blinks briefly and then comes full on. The sensor is ready. If both LEDs blink together, repeat your settings.

2.1

2.3

Photoelectric
Sensors
Accessories
Page 2.3.2 ...

5

Connectors ...
Page 5.2 ...

Recommended accessories

please order separately



Reflector
BOS R-1

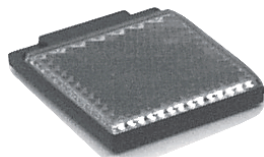

Reflector
BOS R-9



Reflector
BOS R-12



Mounting
bracket
BOS 6-HW-1



Connector
BKS-S 74/BKS-S 75